

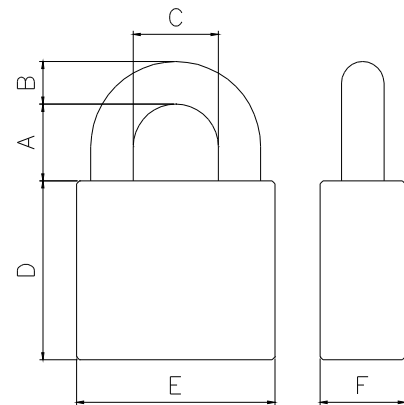

ANCHOR 850-5 Oval

Grade 6 padlock for maximum security applications. Suitable for locking containers, construction machinery, warehouses and heavy sliding doors. The padlock is designed for mounting cylinders of the type Scandinavian oval cylinders. The cylinder is mounted in the same way as an 830-3 padlock. No coverplate is needed. Removable shackle is available as an option for applications with limited space. Another option is the weather protected version with concealed O-rings in the shackle holes.

- > Padlock body: 70mm hardened steel
- > Shackle: 15mm hardened steel
- > Plating: Chrome
- > Cylinder type: Oval
- > Shackle heights: 27
- > Certification: Class 5 according to SSF 014 rev 3.
Grade 6 according to EN 12320:2012
- > Options: Removable Shackle (RS)
Weather protected (WP)

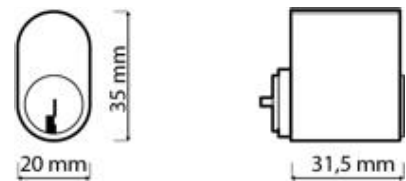

A	B	C	D	E	F
27	15	30	70 / 92 PS	70	30

